

PART OF *EVERY* PROCESS

Quality Components • Technical Expertise • Superior Service



CORPORATE OVERVIEW

2024/25



B-BBEE 2
EMPOWERING SUPPLIER

ISO 9001	Certified
ISO 14001	Certified
ISO 45001	Certified

PROGRESSING WITH PURPOSE

Established in 1974 as a single bearing shop in Durban, South Africa; BMG's aggressive growth strategy has more recently included several strategic acquisitions, supplemented by a steady organic growth discipline.

BMG attracts best-of-breed talent resulting in technical expertise that differentiates BMG in the industry. Staff are truly part of the BMG family and its success. BMG boasts an accredited in-house technical and commercial training academy which fosters a culture of staff development and career advancement; it's all about sustainability.

The net result, is a company that reliably supplies and supports 70 000 customers in 15 countries with the widest range of industrial engineered products and expert services in Africa via 82 branches.

BMG is a level 2 BEE contributor with ISO 9001 Quality Assurance certification. Health and safety of its employees and customers is a paramount focus and the company adheres to OHSAS 18001. BMG is also committed to environmental care and sustainability and strictly follows the ISO 14001 charter.

As a key contributor to the Invicta Holdings stable, BMG has played a major part in Invicta's unique achievement of being rated in South Africa's Top 100 Companies for 21 consecutive years. BMG is positioned to deliver bespoke 360 degree solutions to its customers, and subsequently return on investment to its investors and shareholders.



PART OF *EVERY* PROCESS

BMG plays a pivotal role in supporting the productivity and production targets of all Industrial, Manufacturing, Mining and Agricultural sectors of the economies in the countries it serves.

With an enviable reputation as Africa's largest distributor, manufacturer and service provider of the highest quality engineering consumables and components; including

- Bearings & Seals
- Power Transmission Components
- Drives, Motors & Variable Speed Drives
- Hydraulics, Pneumatics & Filtration
- Heavy & Light Duty Materials Handling
- Valves, Lubrication Systems & Instrumentation
- Fasteners, Gaskets & Tools

BMG has established support divisions which add an unrivalled depth of additional value to our customers. These include:

- **Technical Resources** - Application engineering, design and troubleshooting
- **Field Services** - Mobile breakdown and maintenance support for all disciplines
- **Predictive Maintenance** - Reliability engineering & condition monitoring
- **Academy of Excellence** - Technical & commercial training for customers & staff
- **Supply Contract Management** - Customer contract & on-site store administration
- **Project Engineering** - Project tendering and project supply management



BRINGING THE WORLD'S BEST BRANDS TO YOU

In the bid to procure cutting-edge components at competitive prices, BMG is able to capitalise on long-standing relationships with leading manufacturers dedicated to excellence in design and production.

Products are imported from around the globe and brought to BMG's strategically located distribution facilities and regional service centres via the main distribution hub in Johannesburg - BMG World. A world-class facility boasting 308 000m³ of fully stocked warehouse space, an accredited training facility and unlimited engineering capabilities.

PREFERRED BRANDS



Quality Components

OUR EXTENSIVE COVERAGE THROUGHOUT AFRICA

Products and services are distributed via BMG's extensive distribution network. It's through the sheer size and reach of our infrastructure, that BMG can be found wherever industry has established itself; delivering the correct components at the right time, to the far-flung coalface of our customers' operations.

- Over 300 000 product line items
- Around 4 500 transfers per day out of BMG World in Johannesburg
- Over 1 000 tons of imported stock landing per month
- 82 strategically situated branches throughout Africa
- Vendor Managed Inventory sites (dedicated on-site stockholding)
- International exports
- Locally empowered distribution chains

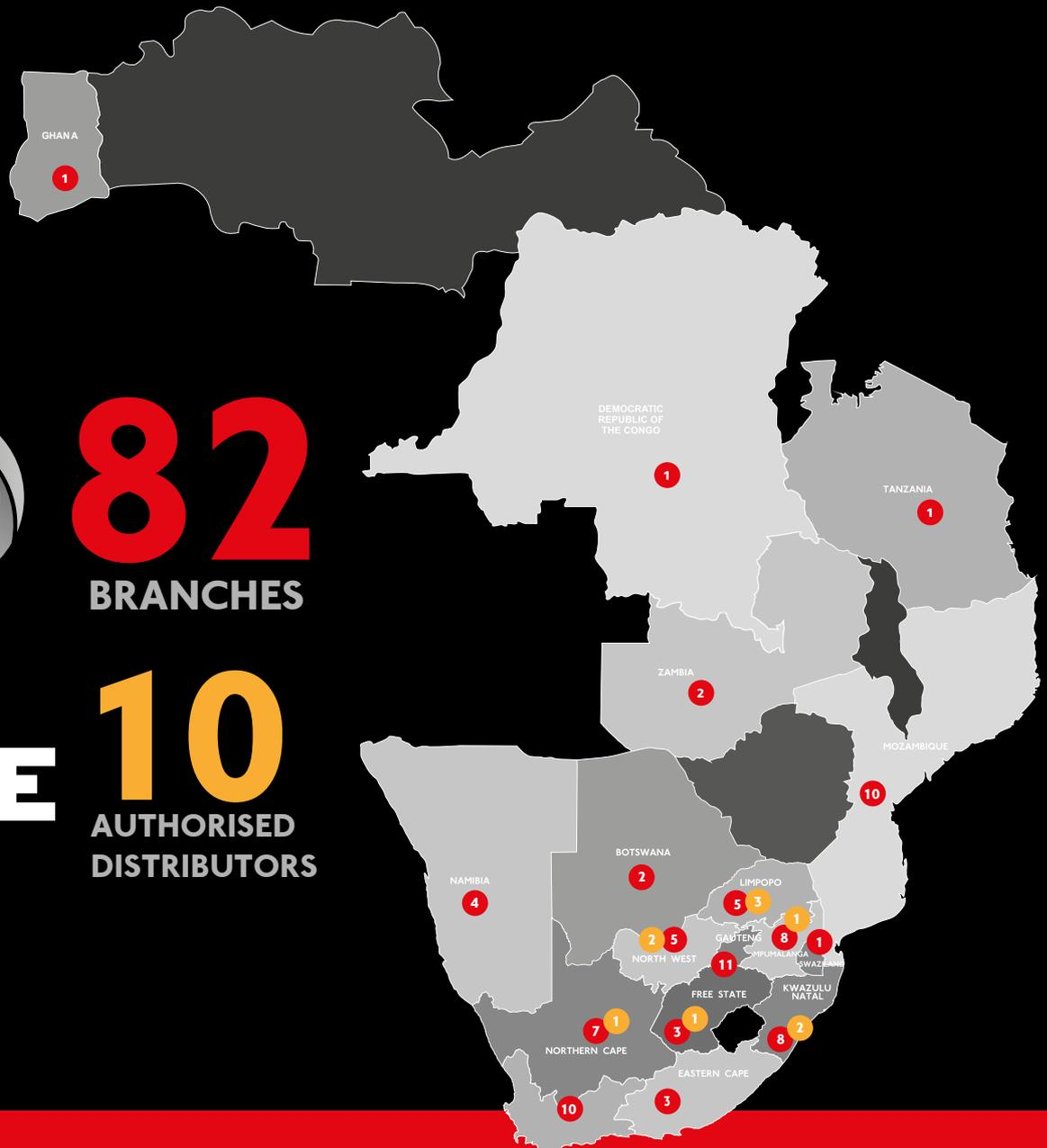

82
BRANCHES



10
AUTHORISED
DISTRIBUTORS

A MINDSET OF CONTINUED LEARNING

We don't merely sell parts.

In order to achieve our vision of truly enhancing every customer's operation - to truly add value - it's essential that our *Quality Components* are also bolstered by real *Technical Expertise*.



To foster this technical expertise, we cultivate a mindset of continued learning and personal development in our people. Our in-house Academy of Excellence is accredited by MERCETA to conduct learnerships, which equip all staff with the skills and knowledge necessary to more effectively meet the needs of our customers and their industry requirements

Through this resource, we train our people and ensure a continual supply of talent into the BMG organisation.



A DEDICATED FIELD SERVICE TEAM



Our Technical Resources team delivers a variety of specialist services on-site, in sync with customer needs for enhanced operational efficiency and maximised productivity. From custom design capabilities, to on-site maintenance and support, plus classroom and hands-on training to enhance customer knowledge.

CORE SERVICES INCLUDE:

- Manufacturing area & capabi
- On-site breakdown maintenance, repair & refurbishment
- Product installation, commissioning & trouble shooting
- Planned maintenance & service contracts
- Preventative maintenance & condition monitoring
- Laser alignment & balancing
- Oil analysis & thermographic studies

SPECIALIST OFFERINGS INCLUDE:

- Customised product design
- System design & evaluation
- Reliability investigation & recommendations
- Energy efficiency studies with suggested improvements
- Project management
- Unitary & bulk materials handling design & installation

Technical Expertise

YOUR PARTNER IN PROJECTS

It is by the virtue of our technical competencies, combined with the quality of our inimitable product offerings, that BMG is able to deliver on the 3rd aspect of our brand promise: Superior Service.

Our dedicated OE projects team manages projects from the initial scope of work to final delivery - all from a single point of contact. Appropriate design, the correct specification of products, performance and delivery are thereby ensured.

PRODUCT MANAGEMENT:

- Product description
- Project specification
- Deliverables
- Documentation - Technical & Commercial
- Comprehensive quotation
- General arrangement drawing
- Microsoft project program at various intervals
- Work breakdown structure
- Subject matter experts throughout our Technical Resources team
- Progress meetings



Superior Service

BRAND PROMISE

Technical Expertise

Staff empowered with the up-to-date Technical Expertise and insight needed to provide component strategies, are better equipped to recommend components that will ensure optimal performance levels for our customers. This is a fundamental point of difference in BMG's customer-focused offering.

Quality Components

Quality Components that our customers can trust, have always been our key offering. As BMG, we are a single, unified source that continues to offer the widest range of high-quality brands.

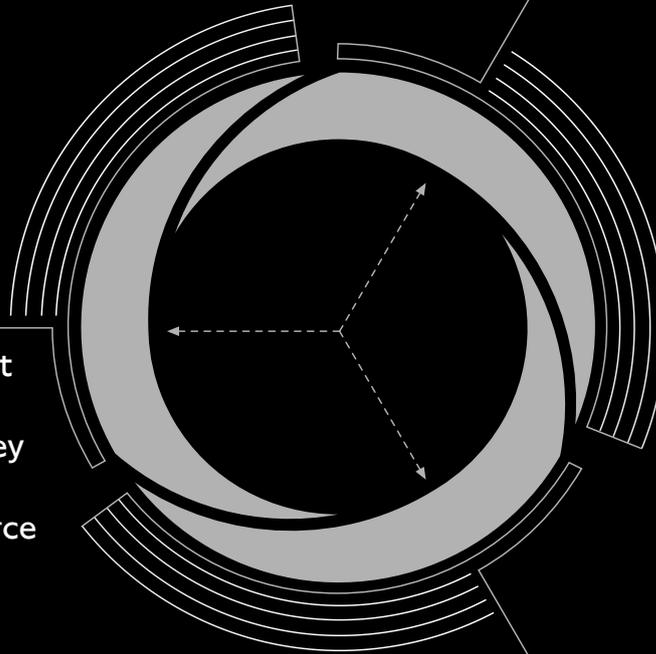

Superior Service

Our customers' success is our success. BMG is committed to providing a Superior Service based on a true understanding of our customers' needs and on delivering to their specific needs professionally and timeously!

- The thin spaces between the interlocking arcs introduce three additional curves that imply a driving, dynamic rotation within the circle.



Dedicated to Brilliant Service

BEARINGS



With the widest range and largest stock holding of Bearings in Africa, BMG is committed to fulfilling the most demanding needs of it's customers.

From miniature to large, ball to taper roller and needle to slewing, BMG has the bearings you need, when and where you need them. Our representation of leading global brands means that you don't have to compromise on quality to experience the most responsive service in the industry.

BMG has developed specialised sealing designs for bearing housings to suit specific industry operating conditions which provides a significant increase in bearing protection. We stock all of the bearing accessories and maintenance tools you're ever likely to need, including bearing installation and removal tools, induction heaters, adaptor and withdrawal sleeves, lubricants, lubricators and lubrication systems.

In addition, BMG's unequalled bearings offer is bolstered by training, design, installation and maintenance services from BMG Technical Resource Division to ensure a full basket of benefits for customers.

BEARING PRODUCTS:

- Ball bearings
- Roller bearings
- Super-precision bearings
- Miniature bearings
- Ball bearing units
- Spherical roller bearings
- Plummer blocks, sleeves & accessories
- Steel balls & rollers
- Needle roller bearings
- Linear way systems
- Ball screws
- Rod ends & spherical plain bearings
- Slew rings
- Split roller bearings
- Thin section bearings
- Bearing pullers & heaters
- Automotive bearings and components

NSK RHP

TIMKEN

NTN SNR

IKO

HKT

TR



SEALS & GASKETS



BMG offers the most extensive selection of seals, gaskets, and seal-related products across the African continent. Our seals play a crucial role in a wide array of industries, ensuring seamless operations in even the most demanding environments. By stocking only the world's leading, innovation-driven seal brands, BMG ensures top-quality solutions for every application. Beyond our broad inventory of sealing products, we provide bespoke seals and gaskets manufacturing through our advanced CNC facilities. This allows us to deliver customized seals and gaskets with exceptional precision, accuracy, and expertise. Our dedicated seals and gaskets product support team is always available to provide on-site advice on seal design, selection, and application. With deep industry knowledge and hands-on experience, they ensure tailored solutions and seamless support for your unique needs. Trust our specialists to deliver exceptional assistance and technical guidance whenever you need it.

SEALING PRODUCTS:

- Rotary shaft seals/Oil Seals
- Torric/Mechanical face seals
- V-rings
- Circlips & kits
- Hydraulic & Pneumatic seals
- Custom-made CNC seals
- O-rings & back-up rings
- Rotary Couplings
- Custom Hydraulic cylinder seal kits
- Mechanical seals
- Gland packing
- Nilos rings
- Bonded washers
- Wave washers
- Bearing isolators
- Expansion joints
- Hydraulic & industrial hose & fittings
- Sealants & adhesives
- Spanjaard maintenance chemicals

GASKETS:

- Graphite gaskets & sheeting
- Rubber gaskets & sheeting
- Cork gaskets & sheeting
- Kammprofile gaskets
- Boiler accessories
- Compressed fibre gaskets & sheeting
- PTFE gaskets & sheeting
- Flexoid gaskets & sheeting
- Spiral wound gaskets
- Halo seal gaskets
- Insulation products
- Expanded PTFE products
- Loctite Gasket Maker
- Custom-made CNC Gaskets



SEALS



POWER TRANSMISSION



As the dominant supplier of mechanical power transmission equipment in Africa, BMG carries a strategic responsibility to keep the wheels of industry turning.

Highest-quality, world-renowned brands like Fenner, Tsubaki and Rexnord enable BMG to design or optimise durable power transmission solutions which deliver extended service life within budgeted time and cost constraints. Our Fenner Drive Selection & Maintenance catalogue has become a “must-have” for maintenance personnel and project design teams nationwide.

BMG has established a facility where special attachment chains are assembled to exact requirements in under a week. A wide range of Tsubaki attachments are available on any suitable American or British chain.

BMG's extensive Power Transmission product range includes Ironware, Chain, Drive Belts and Agricultural Components. This offering is continually being extended through the sourcing of innovative new solutions ensuring that BMG continuously sets premier standards in product and service delivery.

CHAIN:

- Cable carrier chains
- Transmission & conveyor chain
- Mining drive chain
- Drop forged scraper chain
- Elevator bucket chain
- Linear actuators

DRIVE BELTS:

- V & wedge belts
- Powerwrist / Powerlink belts
- Variable speed belts
- Banded belts
- Timing belts
- Poly-V belts
- Synchronous belts

IRONWARE:

- Couplings for all applications
- Full range of pulleys
- Sprockets
- Torque limiters
- Universal joints
- Locking elements
- Taper lock bushes
- Bolt & weld-on hubs
- Agricultural components
- Energy / drag chain
- Cam clutches / backstops

ELECTRO-MECHANICAL



As a leading supplier of electric motors, gear units and variable speed drives, BMG brings together the world's leading brands to provide versatile solutions to industry and mining alike throughout Africa.

From fractional power to Megawatt installations, BMG caters for every conceivable drive requirement. And when production efficiency is your focus, we have the integrated drive solutions and depth of technical expertise to help you reduce your power consumption and maximise your up-time.

Our fully equipped modern workshop and mobile Field Service crews provide the time-critical backup for everything from minor repairs and installations to comprehensive reconditioning services.

GEARS PRODUCTS:

- Helical
- Worm
- Helical bevel
- Planetary gear units
- Cycloidal drives
- Shaft mount speed reducers
- Industrial gear units
- Drive packs

ELECTRONICS:

- AC frequency converters
- Soft starters

MOTORS - EXPLEY LABS APPROVED:

- Single & 3-phase motors
- Cast iron & aluminium motors
- High voltage motors
- Premium efficient motors (IE3 & IE4)
- Pad mount motors
- Brake motors
- Vibrator motors





ELECTRO-MECHANICAL

LIGHT MATERIALS HANDLING



With decades of experience in specialised conveyor and transmission belting, this has given us valuable insight into the choice selection of quality products for the industries unique and diverse applications. The Light Materials Handling Division stocks a wide range of world-renowned products coupled with local value add services and technical support. We are acutely aware that conveyor systems are often at the heart of the manufacturing process and that product reliability, as well as rapid response to unplanned breakdowns are vital qualities that is expected from your Materials Handling supplier.

Our portfolio of products and premium brands from leading component, conveyor and transmission belt manufacturers is our commitment to keeping the industries wheels turning. But that is not all, our six strategically located service centres backs our product offering with world-class fabrication, on-site splicing and maintenance value add services. The combination of regional stockholding, technical support, distribution network and value add services is the winning formula to make your conveyor system complete and operating at maximum efficiency. That is total quality!

In addition to our range of products and conversion services, we also offer technical design and fit for purpose product selection. Our team of technical specialists supports our sales network to make the best product selection for all related applications. These include, plant surveys and audits, product selection and design and condition monitoring coupled to online reporting.

LIGHT MATERIALS HANDLING PRODUCTS:

- Synthetic conveyor & process belts
- Food quality conveyor belts
- Engineered belts
- Endless woven belts
- Belt fasteners
- Modular belting
- Textured plastic homogeneous belting
- Light-duty plied rubber belting
- Wire Mesh belting
- Plastic engineered products
- Conveyor components
- Splicing, assembly and onsite services



MATERIALS HANDLING

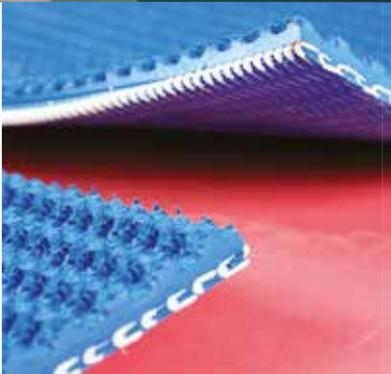

BULK MATERIALS HANDLING

Our Bulk Materials Handling division supplies a wide range of products and services. Through our broad offering, we are well positioned to support world-class products and services to minimise downtime and ensure that production is at the optimal level.

BMG has also taken on a Field Service division. These teams are dedicated to strategic sites and ensure that the product performance, and the investment in that product, is maximised. The Field Service division also can provide additional diagnostic products for Steel Cord preventive maintenance. It is called rEscan. This product can flag any change in steel cord or splice structure thus enabling maintenance ahead of additional expense being incurred through production downtime or expensive belt damage.

Through a reduced total cost of ownership, our customers are enabled to focus on their business with the knowledge that we are ensuring that the conveyor system is functioning efficiently. This is made possible by high-performance products that work harder and longer. We also ensure that this happens through our service offering that includes condition monitoring and preventive maintenance on-site.

We have dedicated product support and technical specialists that are based around South Africa. This includes dedicated, specialised Field Service teams that are available on a 24-hour basis. Our reach extends beyond South African borders into Africa.

BULK MATERIALS HANDLING PRODUCTS:

- Plyed rubber belting
- PVC solid woven belting
- Steel cord belting
- Conveyor frames & idlers
- Elevator products
- Belt fasteners
- Rubber sheeting
- Screen panels
- Trip, alignment & ripped / torn switches
- Diagnostic equipment
- Belt scrapers
- Belt trackers
- Chute & mill liners

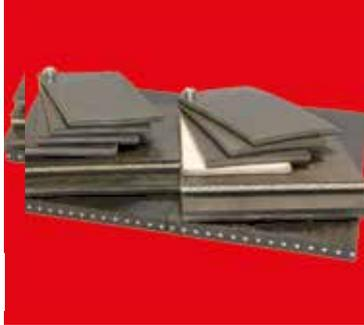
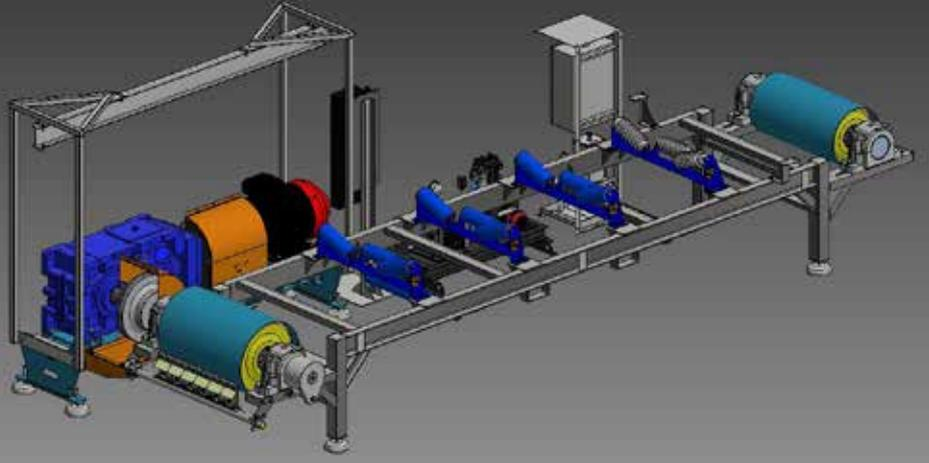

MATERIALS HANDLING



BELTFAST
PLATE BELT FASTENERS

FASTENERS

Through our extensive distribution footprint, BMG offers you easy access to the largest stock holding of Fasteners in Africa. If the product you want is not at your local BMG branch, our central distribution centre at BMG World in Johannesburg, can get ex stock Fasteners to anywhere in the country within 24 hours.

Going one step further, our ability to source non-stocked Fasteners both locally and abroad means that you will never be left without a Fastener solution.

BMG's Quality Management focus ensures that our Fastener products meet the International DIN and ISO standards. Our range includes fasteners in various materials such as: Mild and High Tensile Steel, Grades 4.8 / 8.8 / 10.9 / 12.9, Stainless Steel A2, A4, B7, Titanium and Brass. We stock metric as well as imperial fasteners sourced from various parts of the globe.

Products are available in various finishes including electro zinc, superzinc, mechanical plating, hot-dip galvanizing, geomet and equivalents. Our customer base covers various industries - from Manufacturing, Mining, Construction, Engineering, Truck and Body Building, Rail, Energy, OEM and Wholesale.

BMG is the Distributor of Nord-Lock & Superbolt products in South Africa and neighbouring countries. Our close relationship with these global manufactures and others makes us a solution provider rather than a stockist in the engineering sector.

FASTENERS:

- Bolts & set screws
- Nuts
- Socket head products
- Threaded rod & studs
- Nord-Lock - washers / wheelnuts
- Lock bolts
- Hose clamps
- Grease nipples
- Rivets
- Screw products
- Washers
- Anchors - machanical / chemical / nail-in
- Machined parts
- Lock Bolts
- Superbolt
- Rags



FASTENERS

TOOLS & EQUIPMENT



BMG offers an extensive range of Tools & Equipment encompassing those used in Mining, Manufacturing - heavy & light, Food & Beverage, Timber & Forestry, Chemical and Agriculture. In fact, the range is so diverse we can cater equally for large industrial customers as well as small entrepreneurs.

24 000 article lines are listed, displaying the true diversity of BMG's range. These products are sourced from a variety of global manufacturing partners, thereby ensuring an unrivalled product & distribution network offering.

These products cover the groups; hand tools, abrasives, power tools, maintenance chemicals, lifting & rigging, locks & lockouts, personal protection equipment, welding and even floor level safety.

All products are tried and tested, both locally and globally, ensuring BMG are best suited to offer a fit-for-purpose solution. This can have a direct impact on your inventory optimization and reduced production and maintenance costs. Our house brands offer great quality at an affordable price.

BMG, together with our dedicated supplier base, ensure we are always ready and able to deliver on our brand promise, irrespective of the product group required or the size and location of your business.

TOOLS & EQUIPMENT:

- Toolkits
- Hand tools
- Abrasives
- Bandsaw Blading
- Electric power tools
- Pneumatic power tools
- Personal protection equipment (PPE)
- Locks & lock-out systems
- Cutting & drilling tools
- Electrical test equipment
- Hydraulic tools
- Lifting & rigging equipment
- Cleaning products & absorbents
- Welding equipment & accessories
- Workshop equipment & accessories
- Machine tools - Conventional & CNC





TOOLS & EQUIPMENT



BULK & INDUSTRIAL FILTRATION



Aligned to BMG's focus on improving customers operational efficiencies, are our range of hydraulic fluid, fuel, lubricant, chemical and air filtration products and systems.

The South African filtration market is in-line with international standards and recognises the importance of using ISO 4406 for the cleanliness levels of fuels and oils. The prevention and control of water and particulate contamination is vitally important to the reliability, long-term performance and life extension of machinery and equipment.

With the TK4 & TK5 engines being introduced into Africa, the tolerance levels are getting tighter. BMG assists owners and operators of these equipment by providing solutions to protect vehicles against wear, tear and water damage. Our offering includes complete Coolant, lubricant, fuel, hydraulic, oil and air filters.

Where the contamination ingress is introduced from the beginning of the supply chain, BMG's bulk fuel filtration solutions forms a critical part in the life extension of machinery and equipment reducing total cost of ownership. BMG's Filtration solutions proudly serve a range of industries including Petrochemical, Power Generation, Mining, Agriculture and Manufacturing, capitalising on BMG's extensive footprint in Africa.

FILTRATION PRODUCTS:

- Low, medium & high-pressure filters
- Filter breathers
- Suction filters
- Monitoring equipment
- Bulk filtration systems - fuel & oils
- Mobile / onboard filtration
- On-site installation & commissioning
- Filtration training
- Self cleaning filters





HYDRAULICS, HOSE & FITTINGS



Danfoss, Kawasaki Staffa and Enerpac are just a few of the household names BMG represents. Whether you need individual components, integrated systems or re-engineering and service support, BMG is ready to assist.

We stock the widest range of hydraulic parts in Africa and we constantly review our localised branch stocks to suit the common requirements of the customers in that locality.

Why not let us know your requirements?

Many of our branches are equipped and trained to assemble hose and fittings to replace damaged assemblies.

Contact us for more information.

HYDRAULIC PRODUCTS:

- Accumulators - bladder & diaphragms
- Cylinders - industrial & tie rod
- Heat exchangers - air blast & stack / tube
- Hydraulic motors - gear, vane, orbital & radial piston
- Enerpac hydraulics
- Reservoir accessories - bell housings, couplings, filters, breathers, level & pressure gauges
- Pumps - gear, piston, vane
- Bieri - high-pressure hydraulic equipment

HYDRAULIC SERVICES:

- Hydraulic testing & repair facilities
- Project engineering & consulting
- Mobile service workshop
- Cylinder design & manufacture
- Cylinder repair & testing
- Manifold design & manufacture

HOSE & FITTINGS:

- Danfoss Aeroquip
- Danfoss Winner
- Hose & fittings assembly
- Full pre-fabricated hose assembly centre



HYDRAULICS AND
HOSE & FITTINGS



LUBRICATION SYSTEMS & LUBRICANTS



BMG's range of OMSA lubrication systems for grease or oil significantly enhance the reliability of mining and mineral processing equipment. Lubrication failure is cited as one of the leading causes of machinery downtime.

To combat this, we apply a "Total Process Solution" philosophy to our custom-built integrated systems through the incorporation of all necessary instrumentation and control. Components are also available individually and include pumps, valves and filters as well as instrumentation and control devices.

Our highly responsive service crews will ensure your critical equipment stays correctly lubricated.

Lubricants are substances (usually organic) used to reduce friction between surfaces in contact and by doing this it reduces heat and wear amongst other benefits. The majority of lubricants contain 90% base oil less than 10% additives.

LUBRICATION CAPABILITIES:

- Technical appraisal
- Design
- Engineering
- Manufacture
- System Development
- Site Surveys
- Installation
- Commissioning
- Servicing
- Maintenance
- Repairs
- Condition Monitoring

LUBRICATION PRODUCTS & SERVICES:

- Centralised grease & oil lubrication systems
- Oil re-circulation systems
- Rope spray systems
- Railjet wheel flange lubrication
- Girth gear spray systems
- Air / oil lubrication systems
- Drum pumps for grease & oil
- Drip feed lubricators
- Spring feed lubricators
- Chain lubrication systems
- Field services
- Electro-mechanical lubricators

LUBRICANTS:

- Hydraulic & Gearbox Oil
- Industry specific grade oil
- Pumps
- Grease & lube pumps



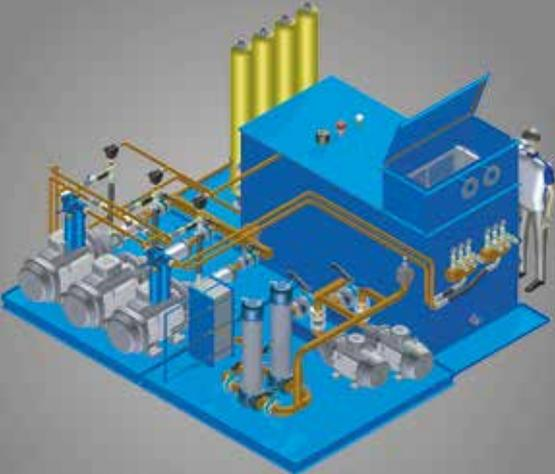

LUBRICATION SYSTEMS & LUBRICANTS



INDUSTRIAL VALVES

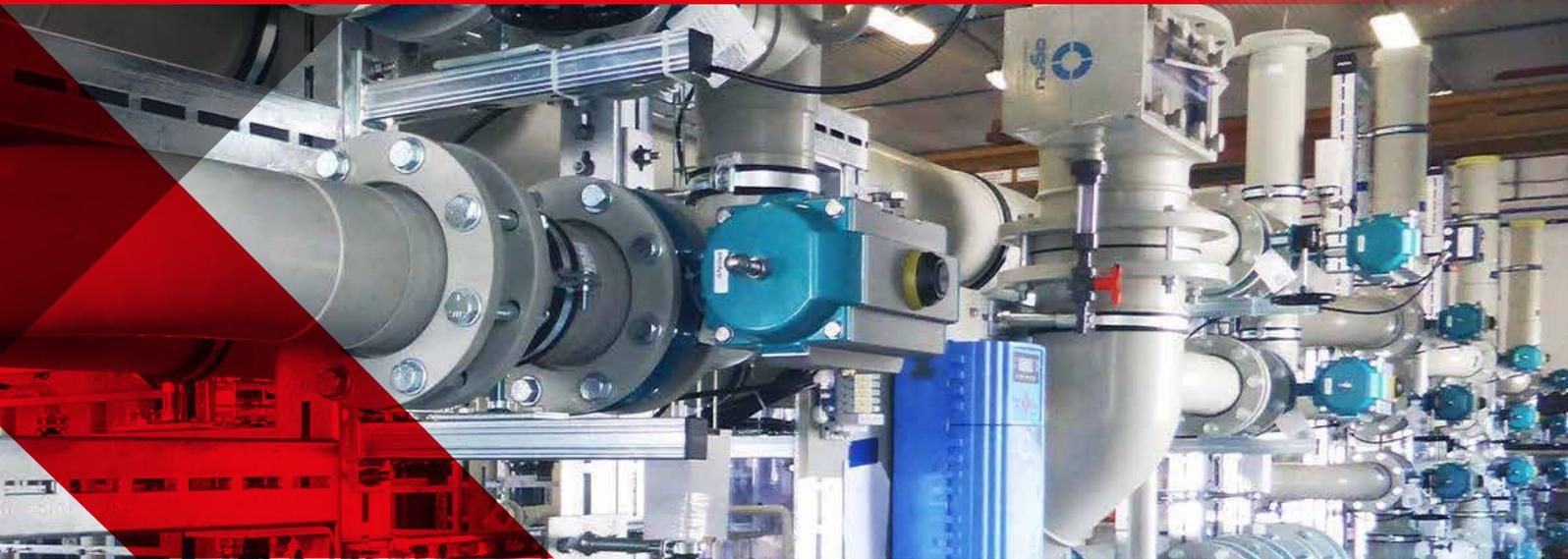

Valves for a wide range of process industries are available from BMG. Expanding from the valves required for lubrication systems, our product offering has grown to include valves for chemicals, water and slurries.

Locally sourced diaphragm valves include the WO Weir type and SO Straight Orifice type. These are rubber lined for high wear resistance and include other linings for a wide range of fluids and applications.

BMG is a supplier of INTERAPP valves manufactured in Switzerland and Spain. The INTERAPP range includes the Bianca Butterfly valve for very corrosive applications and high acid media, as well as the Desponia Butterfly valve with the high temperature EPDM liner for use in the sugar industry and the industrial market.

VALVE PRODUCTS & SERVICES:

- Diaphragm valves - straight through type
- Diaphragm valves - weir type
- Butterfly valves
- Gate valves
- Check valves
- Pinch valves
- Angle seated valves
- Ball valves

ACCESSORIES:

- Pneumatic, hydraulic & electric actuators
- Hand wheel operated gearboxes
- Hand wheel or hand lever for manual action
- Position indicators & limit switches
- Replaceable liners for butterfly valves
- Solenoid valves for coils



© InterApp



VALVES

INSTRUMENTATION

BMG supplies quality instrumentation products from global leading manufacturers. We have exclusive distribution agreements with majority of our world-class partners, who are continually developing new and leading products.

BMG has become a master role player in the field of supplying Industrial Instrumentation to all sectors of the Mining, Manufacturing, Agricultural and Food Industries. We stock the widest range of Instrumentation in Africa.

With the main focus on Lubrication, BMG supply associated instrumentation products and condition monitoring equipment to be fitted on our Lubrication Systems which are built in our workshops located at our BMG manufacturing facility and shipped to a broad spectrum of Industries in Africa and beyond.

BMG provides measurement solutions for process industries and has an extensive range of products for level, flow, pressure, temperature and analytical measurement. Our qualified and dedicated technicians are trained and equipped to meet your Instrumentation needs.

INSTRUMENTATION PRODUCTS:

- Electro-magnetic flow meters
- Doppler flow meters
- Variable area flow meters
- Flow switches & transmitters
- Flow indicators
- Oil flow meters
- Magnetic level gauges
- Level switches & transmitters
- Pressure gauges & switches
- Pressure transmitters
- Hand-held instruments
- Oil quality sensors
- Pressure test equipment

INSTRUMENTATION SERVICES:

- Flow measurement
- Level measurement
- Pressure measurement
- Temperature measurement
- Analytical equipment



PNEUMATICS



BMG supply components and engineering solutions from world leaders in pneumatics, namely Festo, providing quality pneumatic components to suit your every need and to meet your budget requirements.

Our customers' access to the entire range of pneumatics has become so much easier due to BMG's extensive market footprint within Africa. These high-quality components and systems now benefit from the availability and the opportunity for integration with other automation and maintenance components.

Typical processes are Industrial Automation & Equipment, Mobile, Transportation and Food & Beverage applications. Our products have been designed to offer our customers the ultimate in performance, efficiency and reliability.

Pneumatic actuators are manufactured and repaired within our Engineering facilities located in Johannesburg and Durban. 24-hour customer support is offered through BMG's Field Service team, whatever the pneumatic requirement, we've got your back.

PNEUMATICS:

- Pneumatic drives and basic cylinders
- Compressed air penetration
- Vacuum technology
- Electrical connector control technology
- Valves and valve terminals
- Pneumatic fittings and tubing
- Pressure sensors
- PLC technology and software

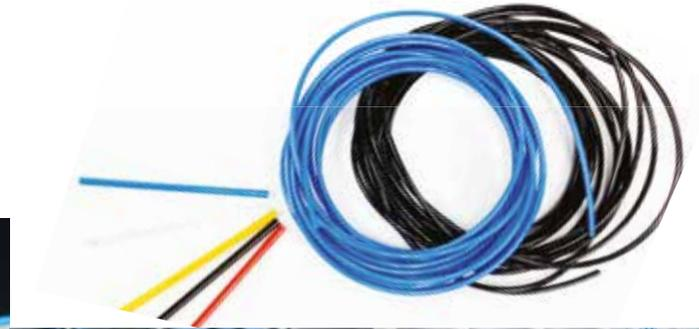
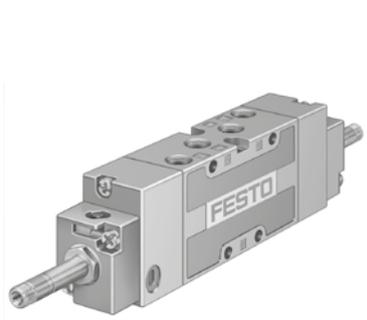

ARGICULTURE



BOERSLIM / SMART FARMING is a concept BMG has developed to demonstrate our commitment in providing you with added value service and product. Through this initiative, BMG's team of agricultural experts offers farming sustainability solutions that focus on effective food production, the correct use of suitable equipment for the specific task and the efficient application of advanced technologies.

We work closely with farmers to demonstrate that their investment in the latest equipment & improved products is necessary to maximise productivity and ultimately translates into tangible operational efficiencies. BMG's range of high-quality BOERSLIM components conforms to relevant quality assurance and specification certifications, and are engineered to improve productivity, to operate efficiently for extended periods and to reduce cost in the long-term.

We have the widest range and stockholding of superior quality products backed by technical expertise and a 24/7/365 day service.

BOER
SLIM

SMART
FARMING

AGRICULTURAL PRODUCTS:

- Agricultural bearings
- Agricultural chain & sprockets
- Drives
- PTO shafts & accessories
- Drive belts & pulleys
- Agricultural gearboxes
- Couplings
- Pivot drive units
- Pivot wheels
- Harrow discs
- Sweeps & ripper points
- Aqua docks





Be PART

24 HR TOLL-FREE EMERGENCY
BRANCH HELPLINE:

0800 022 224

WEBSITE:

www.bmgworld.net



An Invicta Holdings Group Company

BEARINGS • SEALS • POWER TRANSMISSION • DRIVES & MOTORS
MATERIALS HANDLING • FASTENERS & TOOLS • HYDRAULICS
PNEUMATICS • FILTRATION • LUBRICATION • VALVES
TECHNICAL RESOURCES • FIELD SERVICES

B-BBEE 2
EMPOWERING SUPPLIER

ISO 9001	Certified
ISO 14001	Certified
ISO 45001	Certified